



IPX5

CE



IPX4

# **ELECTRIC INSTANTANEOUS DAFI WATER HEATER**

**OPERATING INSTRUCTIONS**

## **Before proceeding with the assembly, it is necessary to become familiar with the instructions!**

**This equipment may be used by children aged at least 8 and by persons with compromised physical or intellectual capacity and persons who are not experienced in and familiar with the equipment, if supervision or instructions regarding the safe use of the equipment is ensured to make the potential risks understandable. Children should not play with the equipment. Children without supervision should not clean and maintain the equipment.**

### **1. General information**

Flow water heaters with bare DAFI heating elements are heaters in which water is heated during its flow through the heater's heating block, in which bare (not insulated) heating elements (heating strands made of resistance wire) are washed by the flowing water and work only during the consumption of water (the power supplies for the heating strands is switched on by a flow connector during the water flow through the heating block). Owing to very small thermal inertia of the heating element, the hot water flows out of the heater immediately after opening the hot water valve.

The water flow heaters with bare DAFI heating elements are heaters with very high energy efficiency of about 98% and energy effectiveness -  $E < 0.125$  kWh/K). In order to heat 1 l of water up to the temperature of 40 – 45°C, DAFI heaters consume only about 0.033 kWh of electricity. As a comparison, for instance, energy efficiency of accumulation water heaters with the capacity of 30 l amounts to about 80% and with the capacity above 30 l - about 83%.

The DAFI heater is provided with the hygiene certificate of the National Institute of Hygiene, "CE" certificate of compliance which gives the title to identify the product with the safety mark "B", "CB Test Certyfikat" issued by Polskie Centrum Badań i Certyfikacji S.A. (Polish Centre for Research and Certification) in Warsaw.

The DAFI heater is provided with the Protection Certificate issued by the Patent Office of the Republic of Poland No. 53535/95.

### **2. DAFI heater characteristics**

The DAFI heater is intended for heating the tap water. It is mounted at water draw-off points of wash basins, kitchen sinks, showers, etc. It may be fixed to one or several hot water draw-off points. The heater is particularly useful in buildings and facilities which are not equipped with the gas installation. We recommend the installation of DAFI heaters at each water draw-off point in order to avoid the water and electricity losses. Owing to very small thermal inertial of the heating element, the heated water is obtained immediately after opening the hot water valve.

The DAFI heaters are manufactured with the following powers: 3 700W; 4 500W; 5 500W; 7 300W for the voltage of 230V and 7 500W; 9 000W; 11 000W for the voltage of 400V. The electricity is drawn only at the moment of water flow, therefore its use is smaller than in storage water heaters. The heating power determines the quantity and temperature of the heated water. By regulating the intensity of the water stream flowing through the heater, it is possible to decrease or increase the water temperature.

### 3. Construction of the water heater

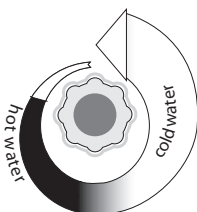
The DAFI heater consists of the heating block placed on the water unit. The water unit is made of the base which is provided with short stub pipes for supply of cold water and discharge of hot water. Inside the heater, there is the heating block provided with water channels with the heating element (heating strand) and elements used for supplying electricity. The whole device is enclosed in an enclosure.

### 4. Operating principle

After opening the hot water valve, the flowing water causes the flow connector to be switched on (power is supplied to the heating element) and the flowing water directed to the tap is heated. Water temperature depends on the pressure and temperature of the water flowing into the heater. The closure of the hot water valve causes the flow connector to be switched off (the power supply to the heating element is interrupted). The temperature of the water flowing into the heater can be adjusted only by closing and opening of the hot water valve slowly within the scope of outflow of the hot water from the heater.

The smaller water flow means the higher temperature.

The temperature of hot water flowing out of the heater is adjusted by closing or opening of the hot water valve slowly.



#### **Equipment of the heater:**

The set to be installed together with the tap: Heater, tap, spout with aerator (fig. 1a), installation wrench, junction box (available as an additional element), operating instructions, list of service centres, guarantee card.

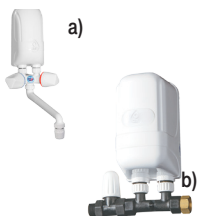


fig 1

Set for the installation with the service connection: Heater, shut-off valve, 1/2" connection, (fig. 1b), installation wrench, junction box, (available as an additional element), operating instructions, list of service centres, guarantee card.

Set for installation with the three-way tap.

Heater, 2 M 18x2/ 1/2" reducing nipples, installation wrench, shut-off valve (available as an additional element), junction box (available as an additional element), operating instructions, list of service centres and guarantee card. For heaters with the power of 3700 W, an aerator and M 22x1/M 24x1 aerator reducer is supplied.

## 5. Principles of heater operation

The properly installed DAFI heater used as intended is completely safe in use. Before the installation of the heater and before putting it into operation, it is absolutely necessary to observe the following conditions:

- the heater cannot be mounted in rooms, where temperature falls below 1°C.
- do not leave the damaged or disassembled heater connected to power supply.
- use the electrical wires with minimum section which corresponds to the rated current of the heater (see also section 6.2 of the instructions),
- observe unconditionally the sequence of connections,
- before connecting the heater to the power source, you must check whether the heater is deaerated (see section 7.1 h of the instructions),
- it is prohibited to use a damaged or faulty device,
- it is prohibited to install the heater in shower enclosures.

Any use of the DAFI heater which is contrary to its purpose causes the manufacturer to not accept the responsibility for the produced damage. The manufacturer does not accept responsibility for the damage and effects resulting from unauthorised modifications and repairs of the heater.

## 6. Sequence for connection of the device to the water supply system and the wiring system.

In the first place, the DAFI water heater must be connected to the water system. Only after deaeration of the water supply system and the heater, the device may be connected to the wiring system.

### 6.1 Connection to the water supply system

The DAFI heaters are low-pressure devices and may operate in water supply networks with the pressure of not less than 100 000 Pa and not more than 600 000 Pa. This may be the municipal water supply system or the local one with a pressure booster, in the case of single-family buildings.

In the case of fluctuations of water pressure caused, among other things, by using automatic flushing valves nearby the heater and in the case of pressure increase above 600 000 Pa, install the pressure reducer.

**WARNING - Do not switch on the heater if it is likely that the water in the heater is frozen.**

### 6.2 Connection to the wiring system

**The heater with the power greater than 3.7 kW must be connected on a permanent basis to the wiring system provided with the earthing terminal.**

## **The heater must be earthed.**

**The connection to the wiring system must be ensured by an electrician provided with an appropriate licence. The heater must be connected to the wiring system performed only in the TN-S or TN-C-S network system (according to 0), with copper wires and cross-section corresponding to the rated current of the heater. The wiring system must be equipped with the switch, that allows the voltage at all poles from the power source to be disconnected**

**The overload protection of the electrical network during the installation of the DAFI electrical flow water heater must be selected in accordance with the rated current of the heater, given in the table with parameters.**

### **Note!**

**If the power cord is damaged, it should be replaced by an appropriate cord available at the manufacturer or at the network of authorised service centres.**

**Each percent of voltage drop below the rated voltage value decreases the heating efficiency by about 2%, and therefore, it decreases the water heating effect.**

## **7. Installation and operation**

The DAFI water heater may be installed with its own tap, with the connection and reducing nipples. In the case of installation with the connection and nipples, it is recommended to install the DAFI shut-off valve at the water inlet to the heater. If the valve is included in the set, it may be purchased in the retail network.

NOTE! The heater cannot be mounted in rooms, where temperature falls below 1°C.

### **7.1 Installation of the heater with its own tap**

a) For the purpose of installation, use only the installation wrench included as part of the equipment. Before proceeding with the installation, close the main water valve and clean the threads. Seal the G ½" thread of the tap body with the locknut screwed on it, using the teflon tape (fig. 2), and then screw it into the fitting protruding from the wall, in order to have the two stub pipes for fixing the heating unit directed vertically upwards.

b) while screwing the tap, maintain particular caution so as not to strip the thread. Do not screw in the tap while holding the knobs with both hands. The correct method of screwing in the tap is shown in fig. 3.

c) The Distance between the face of the nut and the fitting should be 1-4 mm. After establishing the position and distance of the tap, lock the nut by tightening it in the direction of the fitting protruding from the wall (fig. 4).

d) Screw the spout to the tap, screw the fixing nut onto the right stub pipe of the tap (M 18x2), check whether both tap valves are turned off, turn on the

main water shut-off valve, turn on the cold water valve of the heater tap, letting the necessary water quantity move through it in order to remove pollution and air, which are present in the water system.

d) Place the filtering sieve in the left stub pipe of the tap (fig. 6.)f) The heater is mounted on two stub pipes (on top of the M 18x2 tap), and the spout or sprinkling set is mounted on the bottom end (fig. 7).

g) Tighten the nuts of the heater uniformly to the tap, avoiding the tilting of the heater (fig. 8).

NOTE!

h) After connecting the heater to the water supply system, deaerate the heater by opening the hot water tap valve (fig. 9) until the moment of gaining certainty that there is no air in the water system.

i) Switch on the power supply ONLY after the prior de-aeration of the heater as per section 7.1 h (fig. 10)

There is a possibility to install the DAFI water heater on the existing wall bathroom tap or kitchen faucet. In lieu of the spout, the following items can be screw into the tap:

a) an elbow with M 22 x 1.5 and G 1/2" female threads to which the DAFI heater tap is screwed in (fig. 11a).

b) reducer (shower connector) with the M 22 x 1.5 female thread and G 1/2" male thread, to which the G1/2" elbow and then the DAFI heater tap are screwed in (fig. 11b). Further installation operations are the same as in the case of installation of the heater at the end of the water supply pipe running out of the wall.



fig 2



fig 3



fig 4



fig 5



fig 6

## 7.2 Installation of the heater with the connection

In case of installation of the heater with the connection, use only the DAFI heater with the degree of protection against water penetration - IPX4 (fig. 12).

In this system, the connection should be preceded by the DAFI shut-off valve (fig. 13).

In order to install the heater with the connection, the connecting element, which is mounted on the pipe that supplies water is used instead of the tap with the spout.

Before the installation of the heater, install the shut-off valve on the pipe and let the necessary water through it in order to remove the contaminants and the air, which are present in the water system.

Install the connection and fix the DAFI water heater to it. During this activity, it is important to supply the cold water into the stub pipe of the heater in accordance with the marking (arrows) at

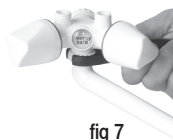


fig 7



fig 8

the back of the heater (fig. 13). Then, open the shut-off valve upstream the heater and the hot water valve on the tap and let out the quantity of water that is necessary to deaerate the heater. The installation of the DAFI heater in this system enables its installation next to the shower enclosure or under the wash basin or sink with the three-way faucet. It also makes the supply of the heated water to several receipt points possible. The heater with the connector may operate in any position.

It is required to close the shut-off valve before the disassembly of the heater or before each operational break longer than 12 hours

### 7.3 Installation of the heater to the three-way faucet

Use only the DAFI heater with the protection degree of IPX 4 for this type of installation.

The DAFI shut-off valve must be installed directly at the inlet of water to the heater.

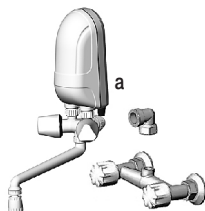
Before the installation of the heater, while turning on the DAFI shut-off valve, let the necessary water flow through it in order to remove the contamination and air which are present inside the water system. Connect the DAFI heater, using the reducing nipples and hoses for the shut-off valve and the tap. Then, open the valve that shuts off the water supply to the heater and the hot water valve on the tap and let out the water quantity that is necessary to deaerate the heater.



fig 9

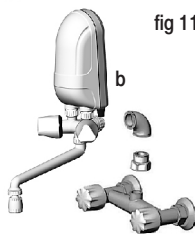


fig 10



a

fig 11



b

## 8. Operation

### NOTE!

Before connecting the heater to the wiring system, deaerate the heater (see section 7.1.h, 7.2 and 7.3). If the air flows out instead of water during the use, close the water supply immediately and disconnect the power supply for the heater. Power supply may be switched on again after the heater is deaerated. Do not switch on the heater, if it is likely that the water in the heater is frozen (as mentioned above in warning from section 6.1).

**The contamination of the aerator may cause:**

- reduction or total disappearance of water outflow,
- excessive heating of water or such decrease in the water outflow which prevents the heater from being switched on.

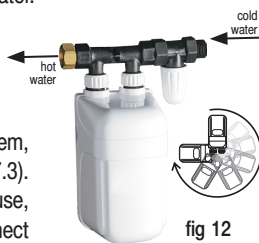


fig 12



fig 13

**It is recommended to clean the aerator of the limescale regularly in order to unblock it.**

The cleaning of the aerator is very simple - it consists in "pushing out" the limescale by pushing in the rubber inset of the aerator (fig. 14). In order to extend the life of the heater, there is a filtering sieve placed in the left stub pipe of the tap. An excessive increase in the water temperature, a significant decrease in the water outflow or lack of outflow may mean the necessity to clean the filtering sieve or to replace it.

**It is recommended to install the DAFI mechanical water filter upstream the DAFI heater**

### **9. Instructions regarding connection to the wiring grid by means of the DAFI junction box (available as the additional equipment)**

The heaters with the power of 3,7 kW, in accordance with the change introduced into EN 60335-2-35/A1:2007, may be connected to power supply, using the non-disconnectable power cable with a socket. Other heaters should be connected on a permanent basis to the wiring system. For such a connection, we can use the DAFI junction box (fig. 15, fig. 16, fig. 17 and fig. 18).

a) Insert the body of the junction box (1) into the standard flushed box for the auxiliary electrical equipment (2) in accordance with the markings on the box (3), then push it so that the body seal (4) could press against the wall on its whole circumference and fix it by means of expansion bolts and screws (5) (a section without a seal at the bottom of the body (6) must remain unsealed, it serves the purpose of discharging the possibly collecting moisture) (fig. 15).



fig 14

b) Connect the heater wire (7) with the wires of the system (8) using the terminal block (9), fix the wire by means of the wire contact (10) and screws (11), push in the terminal block with the connected and fixed wire into the socket (12) in the body of the box (fig. 18). Please pay particular attention to the proper connection of the earthing wire and to provision of the proper electrical connection by strong and solid tightening of the terminals.

c) Place the box cover (13) Slide the cover onto the box from the bottom, along the heater wire until the bottom hinges (14) of the cover are slid under the body of the box, then press the cover strongly to the body making sure that the dowels in the cover (15) are slid into openings (16) in the body of the box (fig. 17).

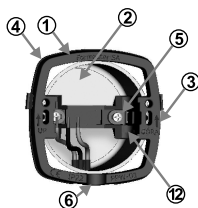
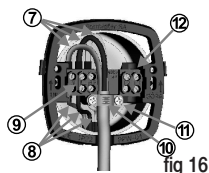


fig 15

d) In order to remove the cover, slide in the slot head screwdriver (17) into the side gap between the body of the box (1) and the cover (13), and turn it by 90°. (fig.18)  
NOTE: In the case of failure to purchase



the original junction box manufactured by our company, it is possible to use a different commercially available junction box.



**DECLARATIONS OF COMPLIANCE FOR THE HEATERS ARE AVAILABLE AT THE FOLLOWING WEBSITE ADDRESS:**

[www.DAFI-heaters.com/pl/](http://www.DAFI-heaters.com/pl/) in the "certificates" tag

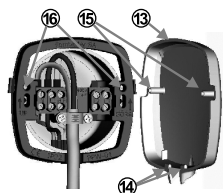


fig 17

**10. Guarantee**

The guarantee period lasts 24 months, commencing from the date of sale of the heater. The defects revealed during the term of the guarantee will be removed free-of-charge within 14 days of the date of delivery of the heater to the authorised service centre, or the manufacturer (the list of service centres is provided in the packaging). The purchaser is obliged to deliver the DAFI heater to the service centre together with the warranty card. The lack of the guarantee card or the damage to the seal causes the loss of the guarantee.

The observance of the principles given in these operating instructions ensures proper operation of the DAFI heater.

**NOTE!**

In accordance with the International Safety Standards, heating equipment should be subject to periodical surveys every 30 months.

The average life of the DAFI water heater, if it is operated in accordance with the operating instructions and recommendations of the manufacturer is about 7-8 years.

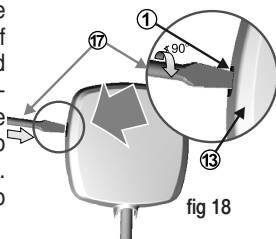


fig 18

**11. Causes of anomalies in the operation of the heater.**

- when the water is heated by the heater insufficiently:

a) check the voltage of the power supply network and rectify the possible causes of voltage drop,

- when the water is heated by the heater excessively:

a) clean the aerator (photograph 16),

b) clean the filtering sieve in the left stub pipe of the tap,

c) check the patency of the water supply system upstream the heater,


- when the heater does not function:

a) check the power supply and possibly check the fuses,

b) check whether the water pressure in the water supply network is not too low, which is revealed by the poor water flow through the heater,

- the cause of breaks in the operation of the heater is:  
a) excessively low or decreasing water pressure in the water supply network.  
The repairs of the device must be performed in the authorised service centre exclusively.

**Information for the user on the  
removal of the waste electrical equipment  
In pursuance of the Waste Electrical and Electronic Equip-  
ment Act of 29 July 2005 (Journal of Laws dated 20 Septem-  
ber 2005, No. 180, item 1495)**

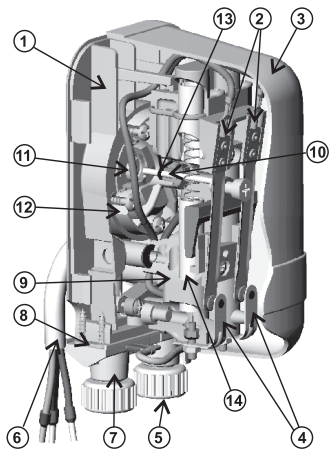
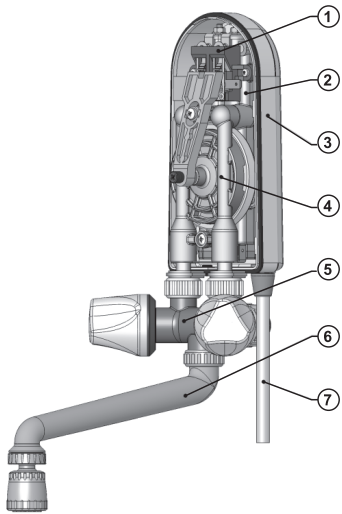
The symbol  placed on the equipment or the packaging indicates that the waste equipment may not be treated like general household waste and that upon ending the operation period, it must be brought to one of the electrical and electronic equipment selection points organised by the public administration.

1) it is prohibited to mix the waste equipment with other waste;  
2) the mixing of the waste equipment with other waste carries a risk for the environment which consists in the increased amount of litter in the environment, as the plastics used in the process of manufacturing the product are materials which are not subject to decomposition, the equipment does not contain any other hazardous components;

3) heating mass - about 1 kg;

At the same time, it is announced that in accordance with the regulations of the aforementioned act, the system for collection of the waste equipment is being organised, at the present stage, it is possible to dispose of the equipment at selected service centres - articles 27 and 28 of the Act.

A household fulfils an important role in contributing to the reuse and recycling of the waste equipment; at this stage the attitudes which influence the safeguarding of the common good which is the clean natural environment are shaped. Households are also some of the largest users of small equipment and its rational management at this stage influences the recycling of secondary raw materials.



- 1. contacts
- 2. base
- 3. housing
- 4. heating element
- 5. tap
- 6. spout
- 7. connection wire

- 1. base
- 2. long contacts
- 3. housing
- 4. short contacts
- 5. connector nut
- 6. connection wire
- 7. connector
- 8. connector seal

- 9. heating element
- 10. membrane tappet
- 11. membrane
- 12. membrane cover
- 13. oring
- 14. ceramic pipe

FT - flow/temperature

## SPECIFICATIONS

[kW] Rated power consumption		3.7	4.5	5.5	7.3	7.5	9	11
[~V] Rated voltage		1/N/PE~ 240V 50Hz				2/PE~ 400V 50Hz		
[A] Rated current		16	19.6	24	31.7	18.75	22.5	25
[A1] Automatic breaker		16	20	25	32	20	25	32
[B1] Water efficiency measured in liters / the minimum temperature of flowing water 15°C and pressure 200 000 Pa	40°C	1.9	2.4	2.9	4	4	4.7	5.8
	45°C	1.7	2	2.5	3.3	3.3	4	5.1

$Q \leq 1300 \text{ cm}^3 - 15^\circ\text{C}$



**IP X4**

Manufacturer: FORMASTER S.A 25-818 KIELCE,  
Fabryczna 24 str., Poland

phone.: +48 41 3464810 ext 123

fax +48 41 3464870

[www.formaster.com](http://www.formaster.com)